

MODEL	TRAVEL	RETR	EXTD	DRIVE HP	A	B	C	D	E	EST WGT
TS44-08	96.00	186.00	282.00	1.5 HP/B	76.88	97.00	37.00	44.00	46.00	C/F
TS44-16	192.00	190.00	382.00	3 HP/B	76.88	97.00	37.00	44.00	46.00	C/F
TS44-24	288.00	194.00	482.00	5 HP/B	76.88	97.00	37.00	44.00	46.00	C/F
TS44-32	384.00	198.00	582.00	7.5 HP/B	76.88	97.00	37.00	44.00	46.00	C/F
TS44-40	480.00	202.00	682.00	10 HP/B	76.88	97.00	37.00	44.00	46.00	C/F
TS44-48	576.00	206.00	782.00	10 HP/B	76.88	97.00	37.00	44.00	46.00	C/F
TS44-56	672.00	210.00	882.00	15 HP/B	C/F	C/F	C/F	C/F	C/F	C/F
TS44-64	768.00	214.00	982.00	15 HP/B	C/F	C/F	C/F	C/F	C/F	C/F
TS44-72	864.00	218.00	1082.00	20 HP/B	C/F	C/F	C/F	C/F	C/F	C/F
TS44-80	960.00	222.00	1182.00	20 HP/B	C/F	C/F	C/F	C/F	C/F	C/F
TS44-88	1056.00	226.00	1282.00	20 HP/B	C/F	C/F	C/F	C/F	C/F	C/F
TS44-96	1152.00	230.00	1382.00	20 HP/B	C/F	C/F	C/F	C/F	C/F	C/F

44.00 DIA PRODUCT INLET WITH (12) 0.88 DIA HOLES ON A 48.00 DIA BC.

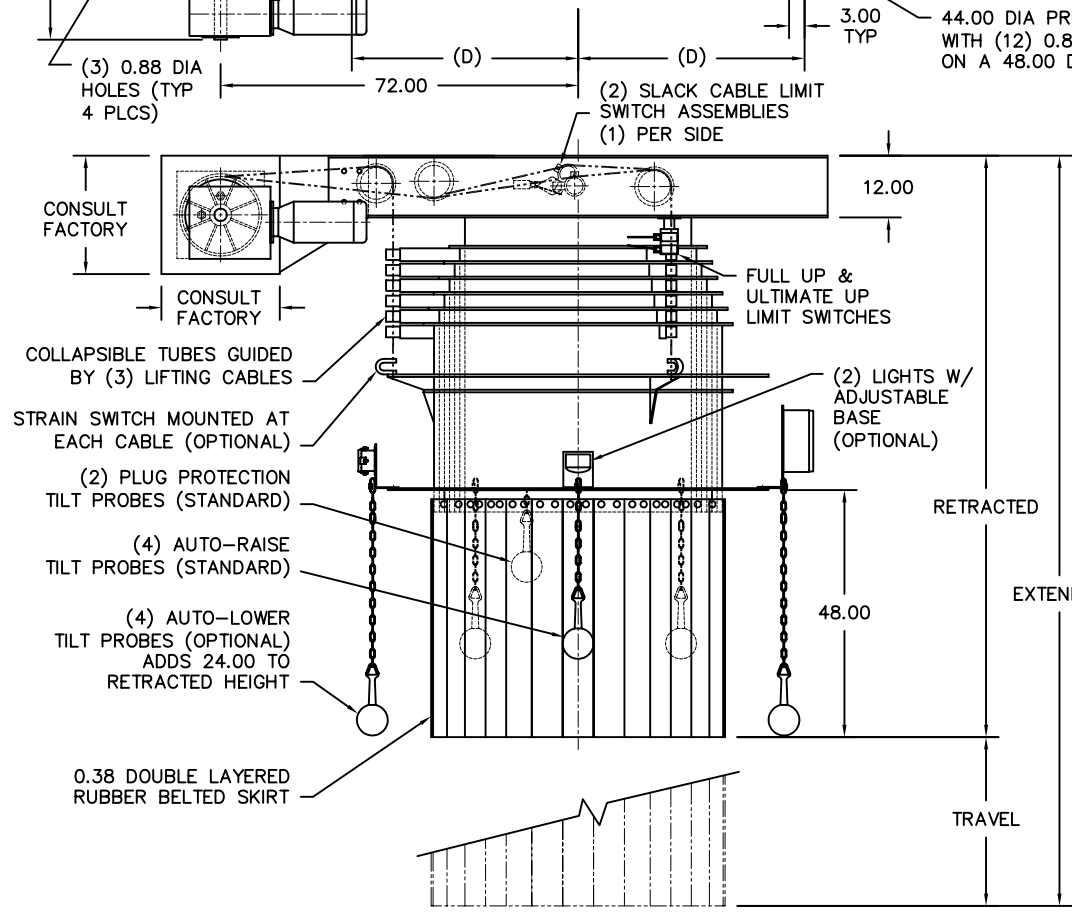

GENERAL NOTES:
 LOADING CAPACITY: 3700 CFM
 LIFTING SPEED: 16 FPM AVERAGE

ALL INDUSTRIAL VOLTAGES ARE AVAILABLE FOR ELECTRICAL COMPONENTS.

PREWIRING OF ELECTRICAL COMPONENTS TO SPOUT FRAME JUNCTION BOX OPTIONAL.

ELECTRICAL ENCLOSURES NEMA 4 STANDARD. NEMA 4X, 7, AND 9 OPTIONAL.

METAL SURFACES ARE POWER TOOL CLEANED:
 (1) COAT EPOXY MASTIC PRIMER, (1) COAT HEAVY DUTY EPOXY, COLOR WHITE

LOADING CAPACITY LISTED IS APPROXIMATE AND BASED ON AVERAGE FLOWING PRODUCTS. CONSULT DCL FOR ACTUAL REQUIREMENTS.

AIR WITHDRAWAL REQUIREMENTS ARE AVERAGE. CONSULT DCL FOR FINAL RECOMMENDATIONS.

SPECIFICATIONS AND/OR DIMENSIONAL DATA ARE SUBJECT TO CHANGE. CONSULT DCL FOR CERTIFIED DRAWINGS.

TUBE CONSTRUCTION NOTES: CONTAINED DESIGN STANDARD WITH 0.25 AR STEEL, AND 0.25 304 OR 316 STAINLESS STEEL. OTHER MATERIALS AVAILABLE TO SUIT APPLICATION.

OPTIONS:
 ROTARY TRIMMING SPOON (SEE DRAWING# RTS-10001)
 ROTARY LIMIT SWITCH, CABLE REEL, PRE-WIRE, SPRAY HEADER

C/F = CONSULT FACTORY

REV	DATE	BY	DCL		SPECIALISTS IN ADVANCED DESIGN LOADING SYSTEMS		P.O. BOX 125 CHARLEVOIX, MICHIGAN 49720 (231) 547-5600		
			TOLERANCES UNLESS OTHERWISE SPECIFIED		DRAWN BY: TLC		SCALE: NONE		
			FRACTIONAL: 1/16" DECIMAL: .06 ANGULAR: 1/2		CHECKED BY: ENG		DATE: 10/06/92		
A	12/02/02	TLC	TITLE: TS44 LOADING SPOUT (OV STYLE)				DRAWING No: TS44-10001		